

MOTORIZED TABLES

ATLAS DUAL-PEDI - A.D.A height - #11382-XX Standard - #11380-XX



ATLAS 2
2-stage pedestal
has a height range of 23"-31"

Double-pedestal tables are known for their strength and adjustability. **The Atlas 2 & 3** are durable and sleek tables with twin anodized aluminum pedestals on a powder-coated carbon steel base. The pedestals can operate independently, allowing the table to tilt. This table's diverse range of motion allows you to position your client in ways not possible on most tables.

STANDARD BASE COLORS:



WHITE POWDER COAT

STANDARD VINYL COLORS:



WHITE ALMOND CAMEL BLACK SLATE PEBBLE



ATLAS 3
 The 3-stage pedestal
has a height range of 20"-34".



Pedestals operate independently to achieve any position.



Ten-button hand control can operate motors independently at the same time.

TOP:

Top design Four-piece adjustable top with round corners, 3-layer foam, 3/4" plywood
 Top adjustments Easy motorized adjustments of torso, knee and upper body sections, plus the entire top can tilt to either end by using independent pedestal heights
 Back tilt angle 0 to 60°
 Knee tilt angle 0 to 30°
 Max tilt angle (entire top) 0 to 18°
 Top adjustment mechanism Two 24v DC, 5 amp max motor/actuators, UL recognized; powered through a 110v, 5 amp transformer
 Main lift mechanism Two 24v DC, 5 amp max motor/actuators for height adjustment (powered through the same transformer as the top actuators)
 Controls 10- button hand control, optional two-button foot pedal.
 Standard size top 30" x 73"
 Foam 2" firm bottom layer + 1- 3/4" medium-density layer of urethane polymer
 Polyester batting 1/2" fluffy polyester Dacron top layer
 Frame 3/4" plywood frame reinforced for armrests and face cradle

BASE & FRAME:

Carbon steel base White powder-coat finish with twin anodized aluminum pedestals
 Leg recess, head end 10" recess from ends of table
 Leg recess, foot end 8" recess from ends of table
 Height Range (Atlas 3, 20"- 34") (Atlas 2, 23"-31")
 Lifting weight Lifting weight capacity 650 lbs.
 Capacity Static weight capacity 1000 lbs.

VINYL:

UltraSoft-Touch Vinyl Lightly textured, super-soft PU vinyl, fabric backed

OPTIONAL ACCESSORIES:

Face Support Contour FaceSpace
 Armrests Flex Armrests
 Foot extension Salon Footrest (6" x 15") or Full Footrest (10" x 24")
 Head/Neckrest Salon Headrest (6" x 15") plus Facial Neck Bolster

GUARANTEES:

Structure 10 yr. on replacement parts for frame/structure and 1 yr. on labor*
 Motor & controls 2 yr. warranty on materials for mechanical/electrical parts
 Vinyl & foam 2 yrs. on materials
 *Labor warranty for USA customers only

WEIGHTS:

Table weight 250 lbs.
 Shipping weight - boxed 350 lbs.
 Shipping dimensions 83"L x 39"W x 37"H

ATLAS 3

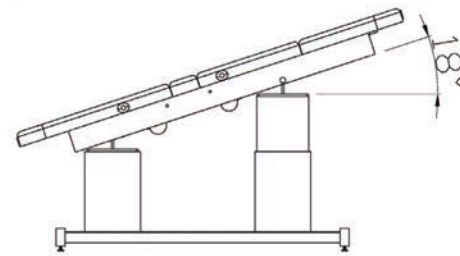
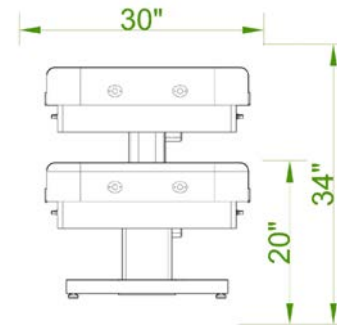
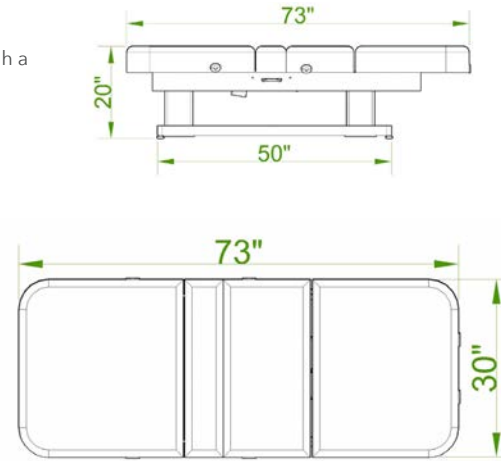

ATLAS 2

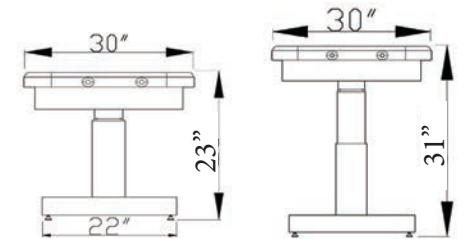
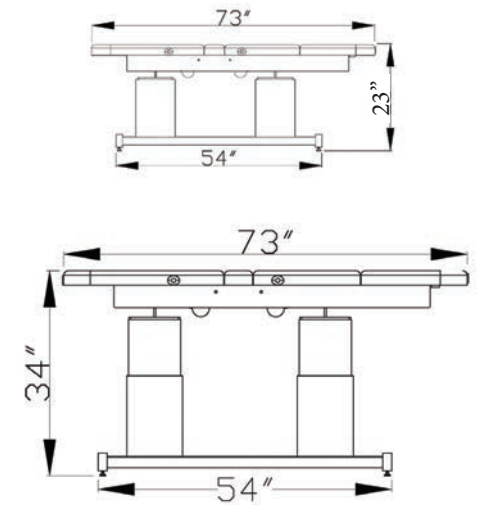

MOTORS & CONTROLS